ELECTRIC CERAMIC TOUCH CONTROL HOB

Installation and Operating Instructions

Model: UEHC602

Your 1 Year Guarantee

Your appliance carries a 1 year parts and labour warranty. To fulfil the conditions of your guarantee, the appliance must be correctly installed, operated in accordance with the instructions and only be used for normal domestic purposes.

Please note that the guarantee and service availability only apply to the United Kingdom mainland.

Customer Service

In case of difficulty please call the Customer Service Helpline number.

0844 800 7848

- When calling customer service, please ensure you have the model and serial number to hand.
- Please keep your receipt or invoice in a safe place as they will be required as proof of date of purchase.

Make a note of the serial number of your appliance here for future reference. You will find this on the rating plate on the underside of the hob:

Serial Number: _____

Appliance 365 Limited, 730 Mandarin Court, Centre Park, Warrington, WA1 1GG

THIS APPLIANCE HAS BEEN DESIGNED FOR DOMESTIC USE ONLY. THE MANUFACTURER SHALL NOT IN ANY WAY BE HELD RESPONSIBLE FOR INJURIES OR DAMAGES CAUSED BY INCORRECT INSTALLATION OR BY ACCIDENTAL DAMAGE OR MISUSE.

USER INSTRUCTIONS

Installation

All operations relating to the installation (eg; electrical connection) must only be carried out by a qualified electrician following the regulations and standards in force. For specific instructions, please read the section 'Installation Instructions'.

Safety Precautions

- To avoid any possible hazard, the appliance should be installed by a qualified electrician only.
- Hot fat is highly flammable so pay extra attention when preparing food with grease or oil. Frying should only be carried out under constant supervision.
- In the event of a fire:
 - Don't take any risks
 - Turn the heat off only if it is safe to do so.
 - Never throw water over a fire.
 - Don't tackle the fire yourself.
 - GET OUT, STAY OUT and CALL 999.
- Warning! Never allow small children in the vicinity of the hob. Older children may use the appliance only under adequate supervision.
- The hob will become hot during use and will remain hot for a period of time afterwards – keep children at a safe distance.

In the event of even a slight fracture on the cooking surface, disconnect the electric power supply immediately and call customer service. **DO NOT USE THE HOB.**

GENERAL NOTES

- We recommend the use of pans which are approx the same size or slightly larger than the heating element (fig. 1).
- When boiling, or when liquid is heated, reduce the heat to avoid liquid boiling over.
- WHEN COOKING FOOD CONTAINING SUGAR, e.g. FRUIT OR JAM, ENSURE THE PAN IS LARGE ENOUGH TO PREVENT SPILLAGE, OTHERWISE THE CERAMIC GLASS WILL BE DAMAGED.
- Do not leave the heating elements on without pans, or leave empty pots or pans on them.
- Do not slide pans into position, lift and place onto the heating element, to avoid scratching the hob surface.
- Do not use the hob as a worktop area and do not chop vegetables on the hob as this will damage the surface.
- Under no circumstances should the hob be used with aluminium foil in contact with the hob surface.

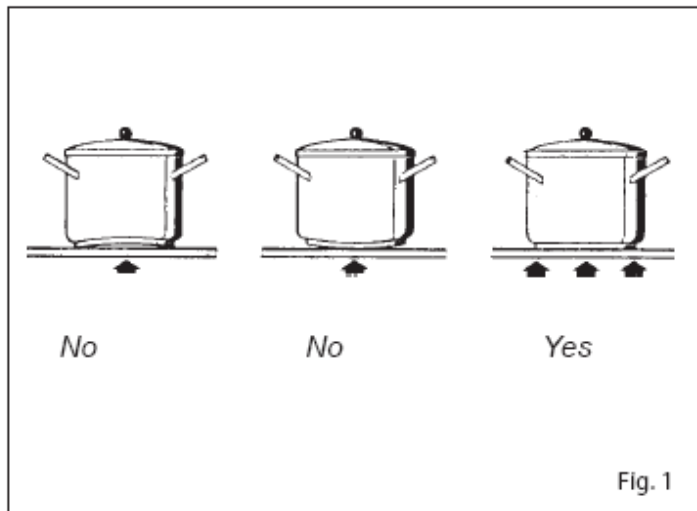

We recommend the use of good quality saucepans with smooth flat bases. Pans with distorted or uneven bases will extend cooking times and could damage the surface of the glass.

How to use the hob

To turn the hob on / off

To turn the hob on, select a cooking zone then rotate the control knob to the power setting required. This hob has 11 power settings labelled 1 to 11. The higher the number, the more powerful the heat as detailed in the table below:

Temperature Setting	Heat Intensity
1 - 2	Weak
3 - 4	Gentle
5 - 6	Low
7 - 8	Medium
9 - 10	Strong
10 - 11	Maximum

Always ensure the control knob is returned to the off position (0) once cooking is complete.

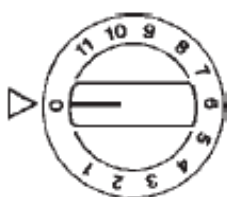

Pilot lights

This model is equipped with a series of pilot lights. When illuminated these lights signify the following:

A – One or more heating elements are switched on.

B – Residual heat indicator confirming that the temperature of the designated element is above 50°C.

Note: In certain instances there may be a slight illumination even after the element has been switched off and the hob is cool. This is quite normal and not a cause for concern or complaint.

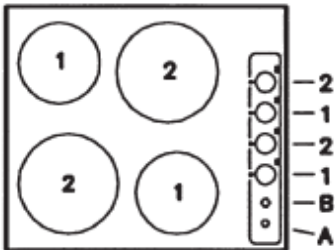

CLEANING AND MAINTENANCE

Cleaning

Before commencing any cleaning or maintenance operation, disconnect the appliance from the electrical supply and ensure the hob is cold.

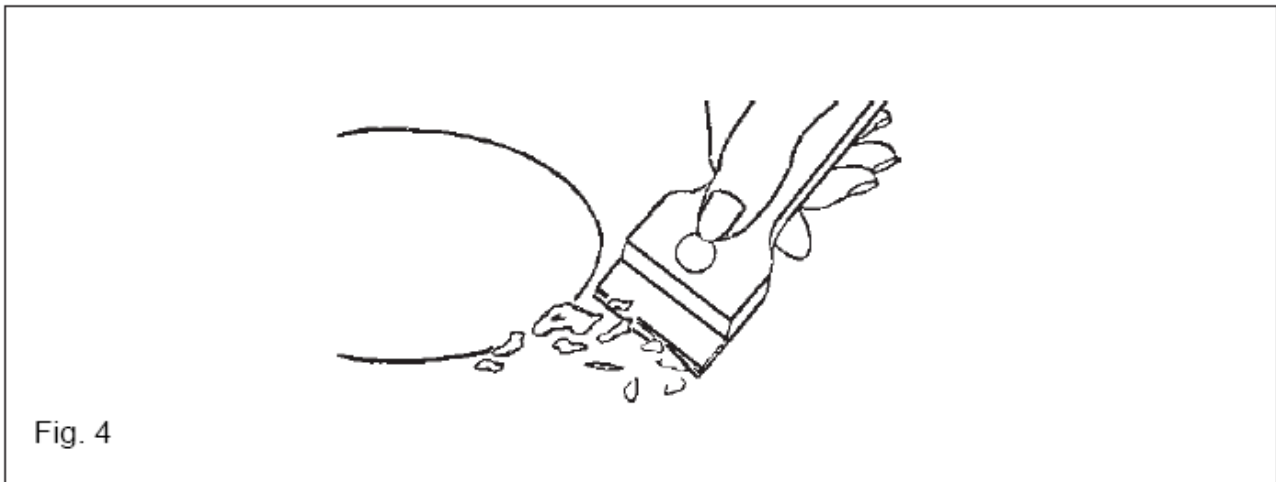

Scraper shown for illustration purposes only

Remove stray bits and grease drops from the cooking surface with a special ceramic hob scraper (fig 4). Ceramic hob scrapers can be purchased from any DIY retailer or Kitchen Specialist. Clean the hot area with “Hob Brite” or another specialist hob cleaner and a paper towel. Rinse with a small amount of water and dry with a clean cloth.

Pieces of aluminium foil and plastic material which have inadvertently melted, sugar remains or foods with a high sugar content have to be removed immediately from the hot cooking area with a special scraper (fig 4). This is to avoid any possible damage to the surface of the hob.

Under no circumstances should abrasive sponges or irritating chemical detergents be used such as oven sprays or spot removers.

INSTALLATION INSTRUCTIONS

Installation

These instructions are for a qualified electrician as a guide to the installation, adjustment and maintenance, according to the regulations and standards in force. The appliance must always be disconnected from the electricity supply before carrying out any of these operations.

The appliance should be fitted into a worktop as illustrated below:

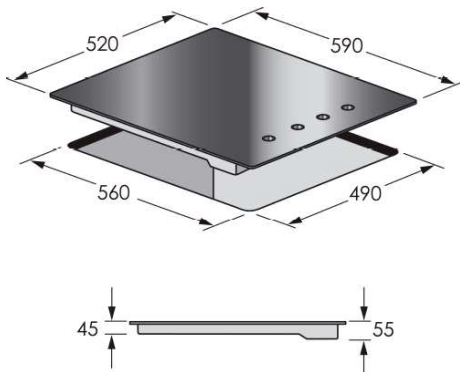

Fitting the Hob

The hob must be installed with the minimum distance around it as shown in fig 6.

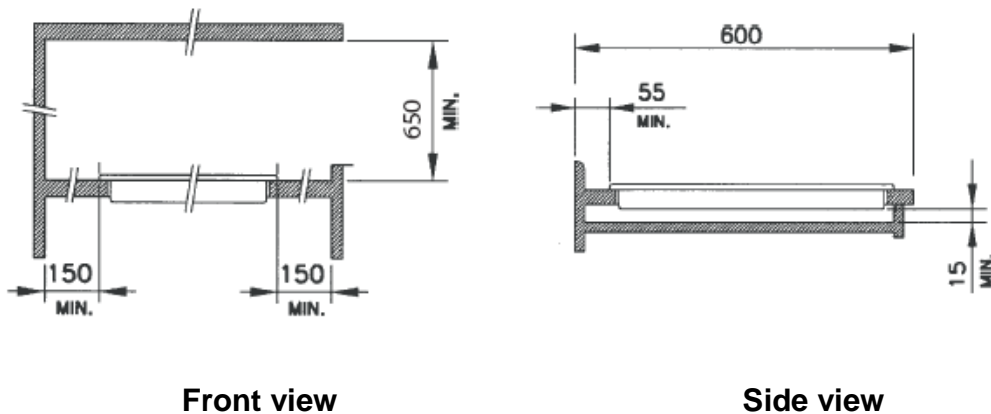

Fig. 6

All dimensions are shown in millimetres.

- Apply the seal to the underside edges of the hob
- Ensure the hob is centralised in the cut-out in the worktop.
- Ensure the clips are fitted in the correct orientation for the thickness of your worktop as shown in Figure 7 and that they grip the worktop before fully tightening.

- Ensure the power supply cable is installed clear of the hob and any other possible heat sources.

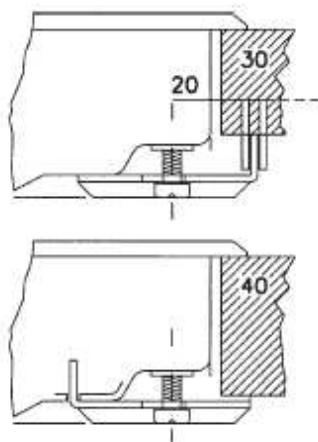
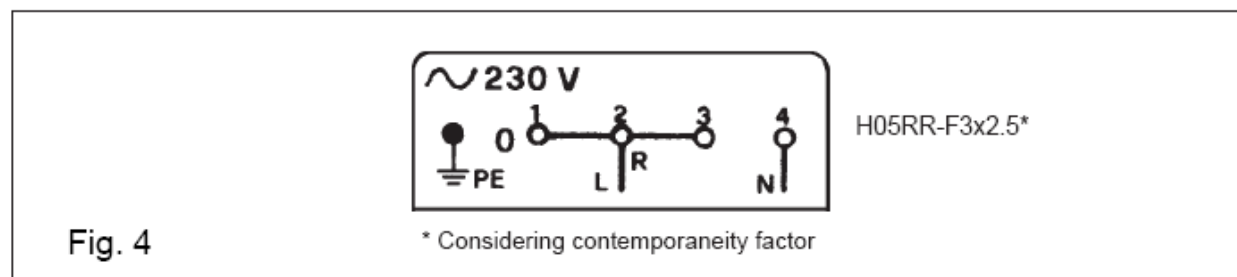

Figure 7

WARNING: THIS APPLIANCE MUST BE EARTHED

Electrical connection



Before connecting the hob to the electricity supply, please ensure that:

- the supply voltage corresponds to the specifications on the data plate, located on the underside of the hob;
- that the mains supply has an efficient earth connection complying with all relevant regulations and standards. The earth connection is a legal requirement. This appliance is not fitted with a power cable, use suitable cables capable of handling the power specified on the hob data plate. The power cable should never reach a temperature 50 °C above ambient temperature at any point along its length.
- if the appliance is to be connected directly to mains terminals, fit a switch with minimum aperture of 3 mm between the contacts. Make sure that the switch is of sufficient capacity for the power specified on the appliance's data plate, and compliant with applicable regulations. The switch must not break the yellow-green earth wire.
- The socket or switch must be within easy reach with the hob fully installed.

The manufacturer declines any responsibility in the event of non-compliance with the instructions above and disregard of health and safety regulations during installation.

TECHNICAL INFORMATION

Heating Elements

Element type	Diameter	Power	Heat settings
Standard x 2	145mm	1200W	1 - 11
Medium	180mm	1700W	1 - 11
Large	210mm	2100W	1 - 11



Appliance365 End User Warranty Conditions

The conditions below outline the prerequisites and scope of the warranty offered by Appliance 365 Limited ("we / us") to consumer end users of appliances supplied by or through us. Please note that these conditions do not affect your statutory rights or the obligations of your retailer and your contract with them.

We provide warranty cover for appliances supplied by or through us for a period of 12 months from the date of delivery of the appliance to the initial end user subject always to the following conditions:

1. The appliance must be correctly installed and operated in accordance with its instructions and only be used for normal domestic purposes. Warranty cover is available only to consumer end users of the appliance; professional or commercial use of the appliance is not covered by this warranty.
2. For the warranty to be valid you must register the warranty together with your details within 28 days of delivery of the appliance to the initial end user. To register the warranty, please follow the instructions on the form included in the document package accompanying your appliance.
3. In accordance with the conditions below (items 4 - 8), defects affecting the appliance which are clearly attributable to material and/or manufacturing faults will be rectified, provided they are reported immediately after being identified and within 12 months of delivery of the appliance to the initial end user.
4. To make a claim under this warranty please contact our customer service department using the number provided in the appliance's service manual, giving full details of the appliance concerned (such as make, model and serial number) and the defect in respect of which the claim is being made. We reserve the right to inspect the appliance following notification of the alleged defect to verify whether a warranty claim is valid in accordance with the terms and conditions of this warranty. You must (wherever possible) retain the appliance in the condition as when the defect was reported until inspection has been carried out. If no defect is identified in the appliance upon inspection a reasonable call out charge may be applied.
5. The warranty does not cover fragile items such as glass or cosmetic parts or consumable items such as light-bulbs. Warranty liability will not be triggered by minor variances from nominal features which are of no significance to the appliance's value or fitness for purpose, or damage caused by the chemical or electrochemical effects of water and generally by exceptional environmental conditions, inappropriate operating conditions, or the appliance having come into contact with unsuitable materials. Likewise, no warranty liability will be accepted if the defects stem from transport damage for which we are not responsible, improper installation and assembly, improper use, poor maintenance or failure to follow operating or assembly instructions or any other instructions or guidance in respect of the storage, use or operation of the appliance. Furthermore, warranty does not apply to any defect arising from fair wear and tear, wilful damage, accident or negligence by the end user or any third party.

This warranty will not apply: -

- a) If repairs or other interventions are carried out by persons not authorised by us to take such action, or if our appliances are fitted with non-original spare parts, extras or accessories; and / or
 - b) In the event of physical or verbal abuse towards any member of our staff.
6. In the event that a warranty claim is verified as valid, warranty provision will be free of charge and we will decide (at our discretion) whether this will take the form of a repair or the replacement of the appliance. All repairs to appliances will be carried out on the premises at which they are installed. Once repair / replacement has taken place, our responsibility under this warranty in respect of that reported defect will be complete. A purchase receipt with date of purchase or delivery must be presented prior to commencement of any repair or replacement. Replaced parts pass into our ownership.
 7. Service may not be available in all of the islands around the UK and Ireland. Please check with your retailer or contact our customer service department.
 8. The provision of services under warranty neither extends the 12 month term of the warranty nor sets in motion any new warranty period. The warranty period for spare parts fitted ends with the expiry of the 12 month warranty on the appliance as a whole.
 9. Nothing in this warranty shall exclude or limit our liability for matters which cannot be excluded or limited by law (for example, but without limitation, death or personal injury arising from our negligence or our fraudulent actions or statements).
 10. Subject to item 9 above, we shall not have any liability in respect of any special, indirect or consequential losses (including for example, loss of salaries or profit, loss of business, loss of income or revenue, loss of goodwill or reputation, loss of anticipated savings or loss of opportunity) except where loss of or damage to your physical property was a foreseeable consequence of our failure to comply with the terms of any contract between us.
 11. This warranty is offered only to the initial end user of the appliance and is not transferable to any other person unless we have agreed to this in writing.
 12. If any court or competent authority decides that any of the provisions (or any part of a provision) of these warranty conditions are invalid, unlawful or unenforceable to any extent, the term (or part thereof) will, to that extent only, be severed from the remaining terms, which will continue to be valid to the fullest extent permitted by law.
 13. These warranty conditions are governed by English law and the courts of England will have jurisdiction in relation to any dispute arising out of them.
 14. These warranty conditions only apply to appliances purchased in the United Kingdom.

The manufacturer declines any responsibility for possible inaccuracies in the present publication attributable to copying and printing errors. The right is reserved by the manufacturer to make such changes to products as are deemed necessary or appropriate, without affecting their essential characteristics.

Model: UEHC602

**Appliance 365 Ltd
Crange House
730 Mandarin Court
Warrington
Cheshire
WA1 1GG**

www.appliance365.co.uk

November 2009